

# Couplings / Gas Analysis



**LINSEIS**

# General

With the coupling of a thermal balance and a gas analyzer like a FTIR spectrometer (Fourier Transform Infrared) or a Quadrupole-Mass-Spectrometer a very powerful analytical instrumentation is used which gives information from the thermal balance (TGA) or simultaneous thermal analyzer (STA) as well as from the spectrometer simultaneously.

The optional Pulse-Analysis injects an exactly predetermined amount of gas into the Thermobalance (TGA) or Simultaneous Thermal Analyzer (STA). This enhances the measurement possibilities significantly.

### Typical couplings for simultaneous measurements are:

- TG-DSC-MS (Thermogravimetry, Differential Scanning Calorimetry, mass spectrometer)
- TG-MS (Thermal balance coupled with mass spectrometer)
- TG-DSC-GC/MS (Thermogravimetry, Differential Scanning Calorimetry, Gas Chromatography / Mass Spectrometry)
- TG-FTIR (Thermal balance coupled with FTIR spectrometer)

### Analytical techniques used for coupling with thermal analyzers

Couplings can be done with different gas analyzing methods:

- FT-IR spectroscopy
- Quadrupole mass spectrometry (QMS)
- ELIF spectroscopy (Excimer Laser Induced Fragmentation Fluorescence)
- Gas chromatography

### Infrared spectroscopy :

Infrared light can excite molecular vibrations in molecules. In order to be active in respect to IR-spectroscopy, the molecule has to change its dipolar momentum during excitation. Gases like CO<sub>2</sub>, CO, hydrocarbons, water vapour etc. have IR-active vibration modes while N<sub>2</sub>, O<sub>2</sub> etc. cannot be detected.

The obtained IR-spectra allow identification of the components by cha-



racteristic vibrations which are either typical for a certain functional group (CO, COOR etc.) or for a particular compound (so called “fingerprint-region” of the spectra from 1500 – 500cm<sup>-1</sup>). Spectra libraries are helpful during spectra interpretation.

Coupling to TGA and STA is a valuable tool especially in analysis of organic compounds (polymers etc.).

#### **Mass spectroscopy:**

Mass spectroscopy sorts molecules by their molecular weight divided by their electrical charge (m/e). In quadrupol mass spectroscopy (QMS) molecules enter a magnetic quadrupolfield after having been accelerated in a static electric field. Molecules and their fragments are sorted by their masses and can be identified. Mass spectroscopy is very useful in order to find the molecular weight of the outgassing as well as to analyse gases which are not active in IR-spectroscopy (N<sub>2</sub>, O<sub>2</sub>, CO etc.). Using mass spectroscopy, nearly all molecules can be detected. Also the resulting fragments of bigger molecules are often characteristic for several compounds or functional groups. This method is a common used analytical method that can be found in polymer or organic analysis as well as in forensic, medicinal, biological or inorganic areas like material science.

Mass spectrometry can be also combined with a GC method that is used to get information about the purity of the substances that are investigated by the mass spectrometer. So the resulting method called GC-MS gives both, purity and molecular weight of the substrate.

#### **ELIF spectroscopy:**

ELIF (Excimer Laser Induced Fragmentation Fluorescence) is a technique used for analysis of alkali metal compounds. Its measuring principle is based on a simultaneous cleavage of molecules, and excitation of the respective alkali atom by a VUV-laser. After the return of the agitated atom to its original state, a photon of a characteristic wavelength is emitted. The intensity of this “fluorescent signal” is a measure of the concentration of the compound in question. This technique is a valuable tool for characterization of alkali metal compounds (NaCl, KCl, NaOH, etc.).

ELIF spectroscopy can be used only by optical in-situ coupling (see below).

#### **Gas chromatography**

The evolved gases can be a complex mixture of compounds. Column Chromatography separates these compounds before analysing them by different techniques. The chromatographic separation column has to be chosen according to the type of molecules to be separated (polar or unpolar). The most frequently used detection techniques are flame

ionization detectors (FID) and thermal conductivity detectors (TCD).

### **Type of couplings**

The coupling of the thermal analyser with the spectrometer/chromatograph can be done by different means:

- Heated transfer capillary (FTIR, GCMS, GC, MS)
- Sniffer coupling (GCMS, GC, MS)
- Optical in-situ observation (ELIF)

#### **Heated transfer capillary**

The simplest way to do a coupling is by heated capillary. In this case, a heated capillary feeds the evolved gazes from the thermobalance to the spectrometer or chromatograph. The internal diameter of a capillary is < 0,1 mm in case of a MS coupling. The capillary is heated to 200-300°C which results in the risk of condensation of outgassing during transfer and clogging of the capillary.

#### **Sniffer coupling**

This technique is used for mass spectrometer coupling. Gases pass through a very small orifice close to the sample inside the furnace and are transferred in the vacuum line to the mass spectrometer. In this way, gases are sampled at high concentration very close to the sample at high temperature and pass directly to ultra-high vacuum. This technique avoids any risk of condensation during transfer between the thermobalance and the mass spectrometer.

#### **Optical in-situ observation**

In this case, optical windows are integrated in the thermobalance's. During heating samples often undergo phase transitions and/or weight change due to evaporation of solvents and/or chemical reactions. These changes can be detected by thermal analysis: calorimetric techniques (DTA and DSC) give information about the heat involved in these processes and thermogravimetry (TG) shows the weight change.

Weight change can be either weight increase due to oxidation reactions or weight loss due to decomposition by liberation of volatile compounds. Analysis of these evolved gases can give valuable information about the sample composition and reaction pathways for decomposition. As thermal analysis gives no information about the nature of the evolved gases, coupling with spectrometers or chromatographs is a valuable tool for evolved gas analysis (EGA).

Mass spectrometry (MS) is an analytical technique to measure the mass of atoms or molecules of a gas e.g. evaporated from a sample material which has been heated up. The spectra are used to determine the elemental or isotopic signature of a sample, the masses of particles and of molecules, and to elucidate the chemical structures of molecules, such as peptides and other chemical compounds. Mass spectrometry works by ionizing chemical compounds to generate charged molecules or molecule fragments and measuring their mass-to-charge ratios.

The QMS - quadrupole mass spectrometer coupling device is a state of the art mass spectrometer with a heated inlet system. The QMS is used for the analysis of volatile decompositions. All LINSEIS instruments are especially designed to guarantee a user friendly operation of both the thermal analyzer and the mass spectrometer. An integrated Software solution is certainly available.

#### **Example System: Coupling of thermo balance TG/STA + Quadrupole Mass-spectrometer(QMS):**

Both manufacturers LINSEIS and Pfeiffer are some of the leading companies in their specialized fields. This cooperation guarantees outstanding performance for the combined system.

- Transfer line is temperature controlled up to a maximum of 250°C.
- Fast response time through short transfer line
- MS detector with very high sensitivity and with different mass numbers available.

#### **The following applications can be measured:**

- Outgassing components of burned material (paints etc.)
- Determination of blenders and additives
- Absorption and Desorption processes
- Analysis of rubbers and plastics

#### **Features**

- LINSEIS Research balance (different models) with TG or simultaneous TG/DSC or TG/DTA measurement
- Simultaneous balance with (0.1/0.5/1µg) resolution and 25g max. sample weight
- Specific heat measurements (Cp) possible
- Pfeiffer/Balzers mass spectrometer model Thermostar (0 - 100 amu, 0 - 200 amu, 0 - 300 amu)
- Highest precision Quadrupole-MS from world leader in MS Technology
- MS with very compact dimensions
- Very easily exchangeable quartz capillary
- Three separate heating zones, at capillary, at TG protection tube and at MS vacuum inlet
- Carrier gas with wide range of flow rates
- Especially developed Al<sub>2</sub>O<sub>3</sub> "sniffer-nose", to extract the outgasings
- Combined results of TG and MS available in one evaluation sheet
- Complete vacuum tight system





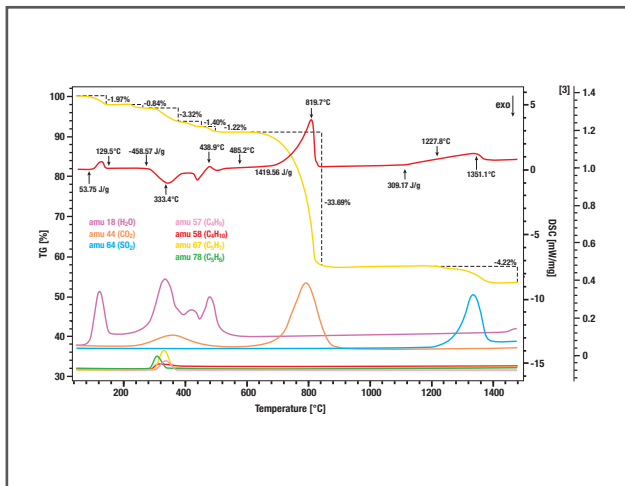

## Cement raw material

The combination of thermal analysis with mass spectroscopy is a very powerful method to identify and quantify the components of the raw material and it is also a tool for the simulation of the manufacturing process of building materials. The components of cement raw material are: mixture of ceramic components (gypsum, calcium carbonate, etc.) and also organic components.

### Analysis using STA and QMS

The picture shows the simultaneous thermogravimetry (TG) combined with differential scanning calorimetry (DSC) and mass spectroscopy (MS). The mass spectrometry allows the identification of the evolved gases from the material.

Mass spectrometry shows peaks from H<sub>2</sub>O at low temperatures most probably from gypsum. The DSC peaks and the signal from mass spectrometer between ~300°C – 400°C indicates the decomposition of organic components. The peak of CO<sub>2</sub> at ~800°C indicates the decomposition of CaCO<sub>3</sub>. At ~1300°C CaSO<sub>4</sub> decompose (SO<sub>2</sub> – Peak).

## Decomposition of CaC<sub>2</sub>O<sub>4</sub>

The evolved gases from the decomposition of calcium oxalate have been fed into the mass spectrometer with a heated capillary. The ion currents for mass numbers 18 (water), 28 (carbon monoxide) and 44 (carbon dioxide) have been imported into the graph.

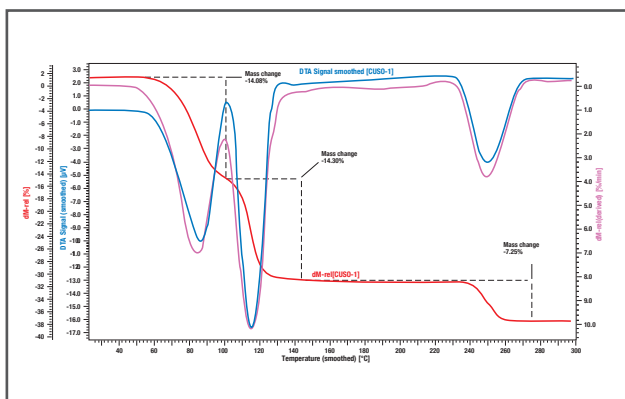
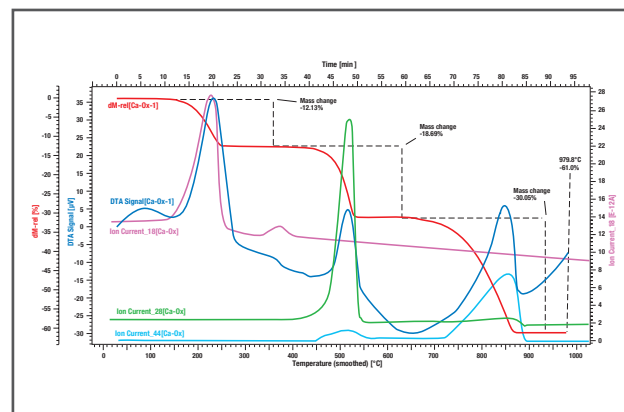

## Mass spectrometry of roof tile clay

The Fourier transform infrared spectroscopy (FTIR) is a technique which is used to obtain an infrared spectrum of absorption, emission, photoconductivity or Raman scattering of a solid, liquid or gas. An FTIR spectrometer simultaneously collects spectral data in a wide spectral range. This confers a significant advantage over a dispersive spectrometer which measures intensity over a narrow range of wavelengths at a time. FTIR has made dispersive infrared spectrometers all but obsolete, opening up new applications of infrared spectroscopy.

The combination of a Linseis Thermal Analyzer with a FTIR is especially interesting in fields such as polymers, chemical and pharmaceutical industry. The coupling is more than the sum of the separate parts. Benefits come from the LINSEIS coupling knowledge and integrated hard- and software concept. For interpretation different libraries are available.

#### **Possible Couplings:**

Thermobalance + FTIR Spectrometer in the temperature range from -170°C up to 1750°C

- L81/I-FTIR Thermo balance + FTIR Spectrometer
- L81/II-FTIR Thermo balance + FTIR Spectrometer
- STA PT 1600-FTIR Thermo balance + FTIR Spectrometer
- STA PT 1000-FTIR Thermo balance + FTIR Spectrometer

Thermobalance with coupling to Nicolet FTIR spectrometer. The coupling is made with a heated capillary.

#### **Features**

- Research balance (different models) with TG or simultaneous TG/DSC or TG/DTA measurement.
- High precision Nicolet FTIR spectrometer (different model available).
- Temperature range -170°C up to + 1750°C Three separate heating zones, at capillary, at TG protection tube and at FTIR measuring cell.
- Carrier gas with wide range of flow rates. Especially developed JLF-detector with long optical pass length.

#### **Description**

Both manufacturers Linseis and ThermoFisher Nicolet are some of the leading companies in their specialized fields. This cooperation guarantees outstanding performance for the combined system.

- Transfer line is temperature controlled up to a maximum of 250°C.
- Fast response time through short transfer line.
- FTIR detector with very high sensitivity and with different wave numbers available.

The following applications can be measured: outgassing components of burned material (paints etc.), determination of blenders and additives, absorption and desorption processes, analysis of rubbers and plastics.

## Cement

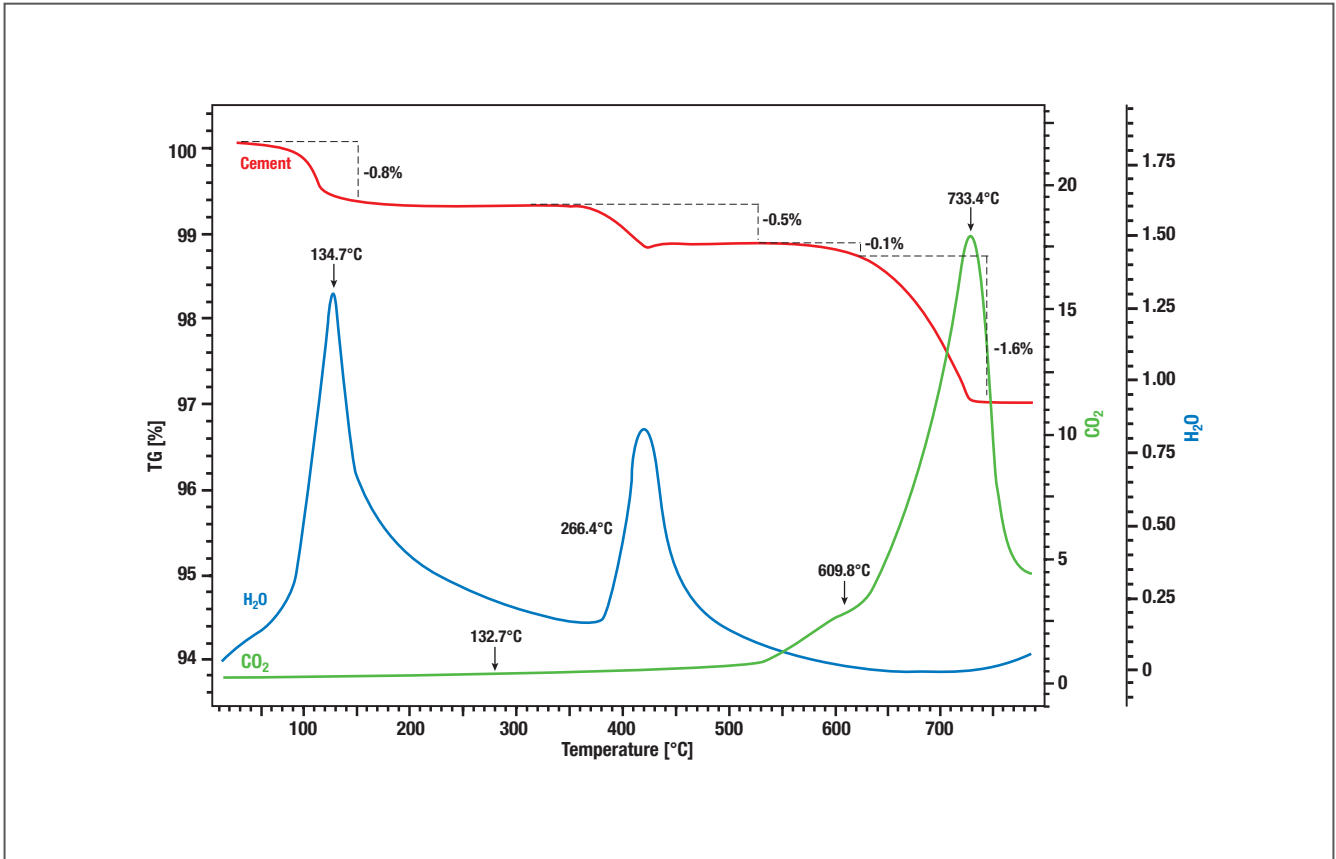

### Introduction and application

Cement is an inorganic, non-metallic material. Together with water it hardens and afterwards it stays also hard under water. Portland cement consists of limestone, clay and/or sand. The additives gypsum, anhydrite etc. influence the setting time of the cement. Impurities in the raw cement cause negative influence on the quality of the cement.

### Analysis using thermogravimetry and FTIR

The additives can be identified and quantified with thermal analysis. The first step shows the evolved water from the CaSO<sub>4</sub> di-hydrate to CaSO<sub>4</sub> half-hydrate. The second step is the conversion of the CaSO<sub>4</sub> half-hydrate to the CaSO<sub>4</sub> anhydrite. The evolved water can also be verified by FTIR analysis. Between 600°C and 750°C the carbonates decomposed so CO<sub>2</sub> evolves. The shoulder in the CO<sub>2</sub> trace of the FTIR signal is the decomposition of MgCO<sub>3</sub>.



# MS-Sniffer

Due to the limitation of the input pressure of the MS, the sample gas must be taken after the pressure controller (at ambient pressure). So, only substances which can pass through the cold trap can be analyzed.

The outgassings of the sample are passed to the QMS-analyzer directly, using a very small aperture. This small aperture (or orifice) reduces the pressure inside the pressure vessel to the input pressure allowed

for the QMS. Since this aperture is inside the hot zone of the furnace, condensation of the outgassings can't take place. Since between the aperture and the ion-source of the QMS a vacuum of app.  $1e-5$ mbar exists, condensation there is impossible also.

The sniffer is placed directly above the sample. This is possible because of the the sniffer material, which can resist the temperatures in the hot furnace area.

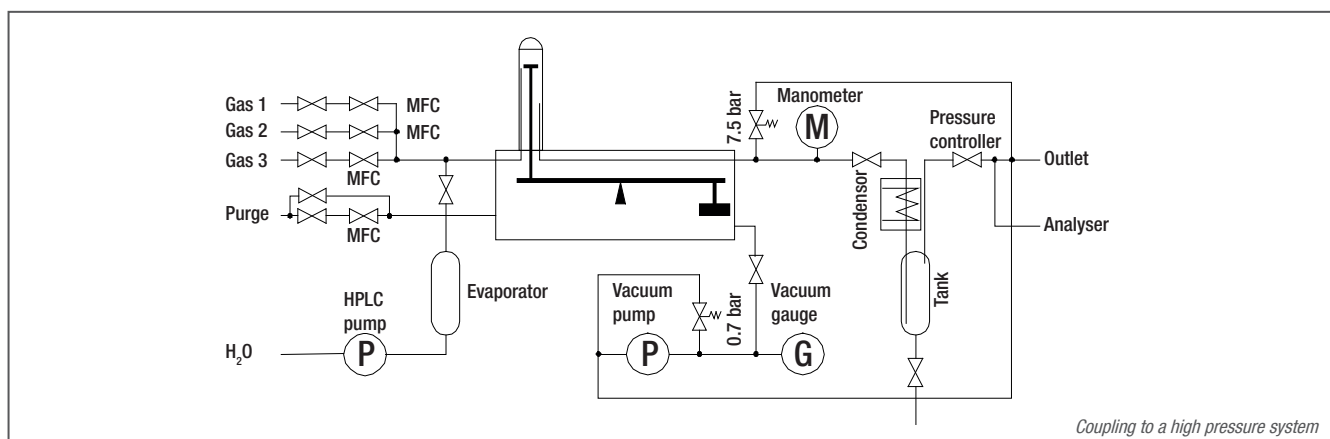
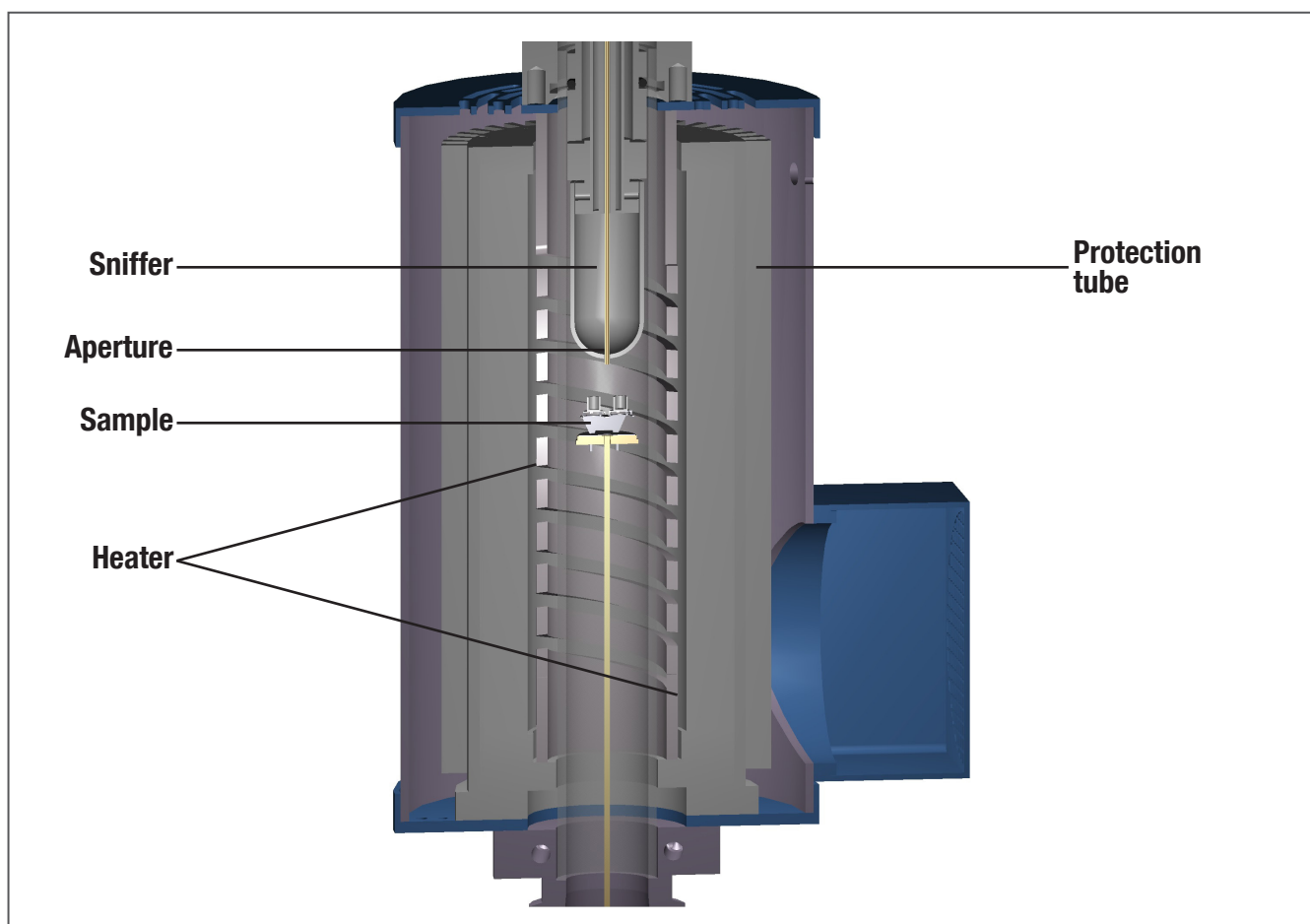



# GCMS

During heating samples often undergo phase transitions and/or weight change due to evaporation of solvents and/or chemical reactions. These changes can be detected by thermal analysis: calorimetric techniques (DTA and DSC) give information about the heat involved in these processes and thermogravimetry (TG) shows the weight change. Weight change can be either weight increase due to oxidation reac-

tions or weight loss due to decomposition by liberation of volatile compounds. Analysis of these evolved gases can give valuable information about the sample composition and reaction pathways for decomposition. As thermal analysis gives no information about the nature of the evolved gases, coupling with spectrometers or chromatographs is a valuable tool for evolved gas analysis (EGA).

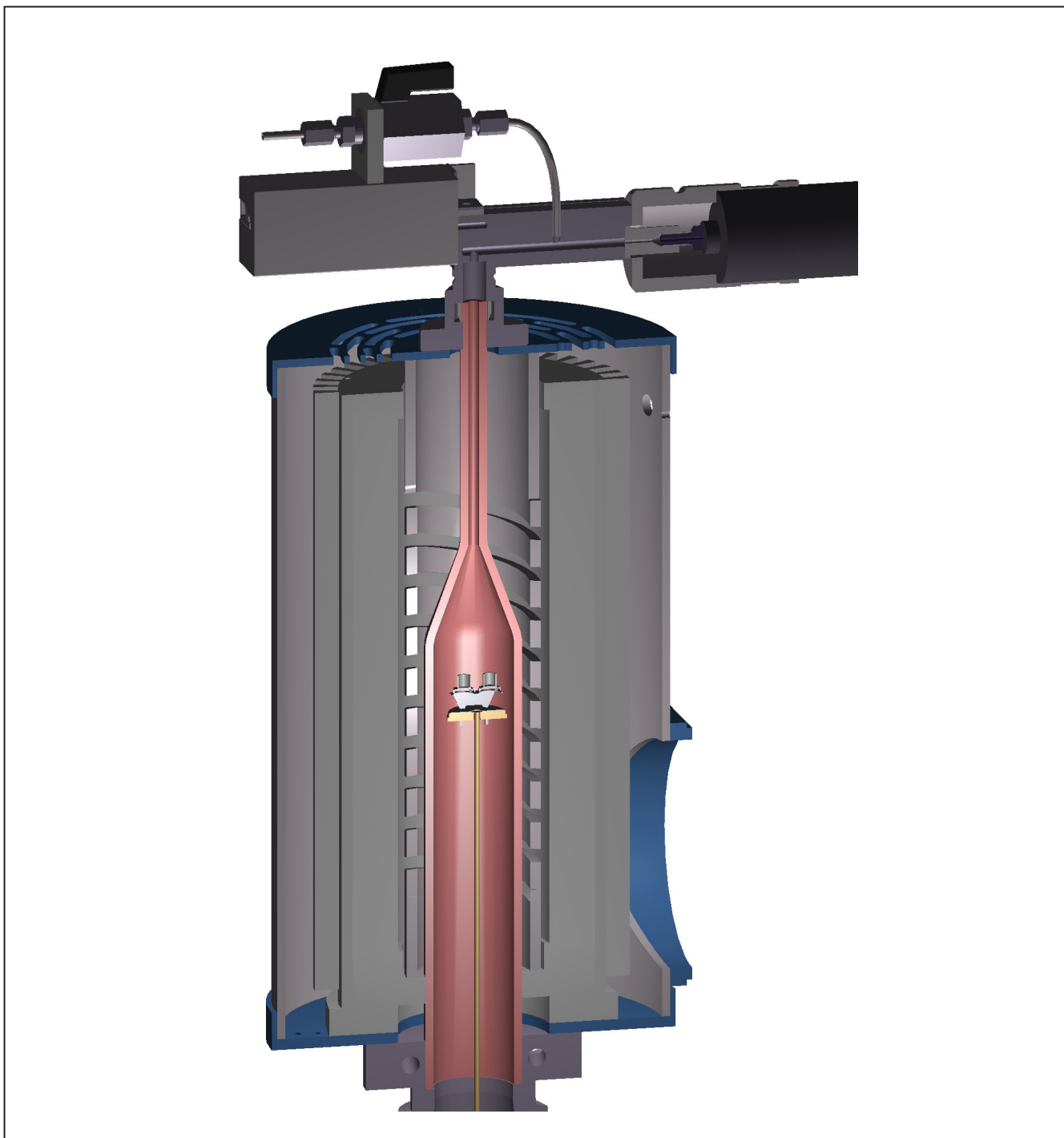

## Thermal decomposition of latex

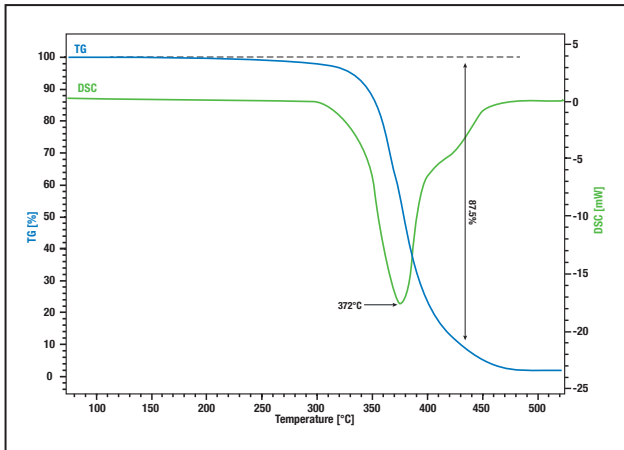

At 370° synthetic rubber decomposes into some monomer parts. The main parts limonene and isoprene can be identified using STA combined with GC-MS. The STA signal shows mass loss and enthalpy change at 372°. At the same time the GC shows two peaks, a smaller and a bigger one, where the smaller one can be identified by mass spectrometry as isoprene and the bigger one as limonene.

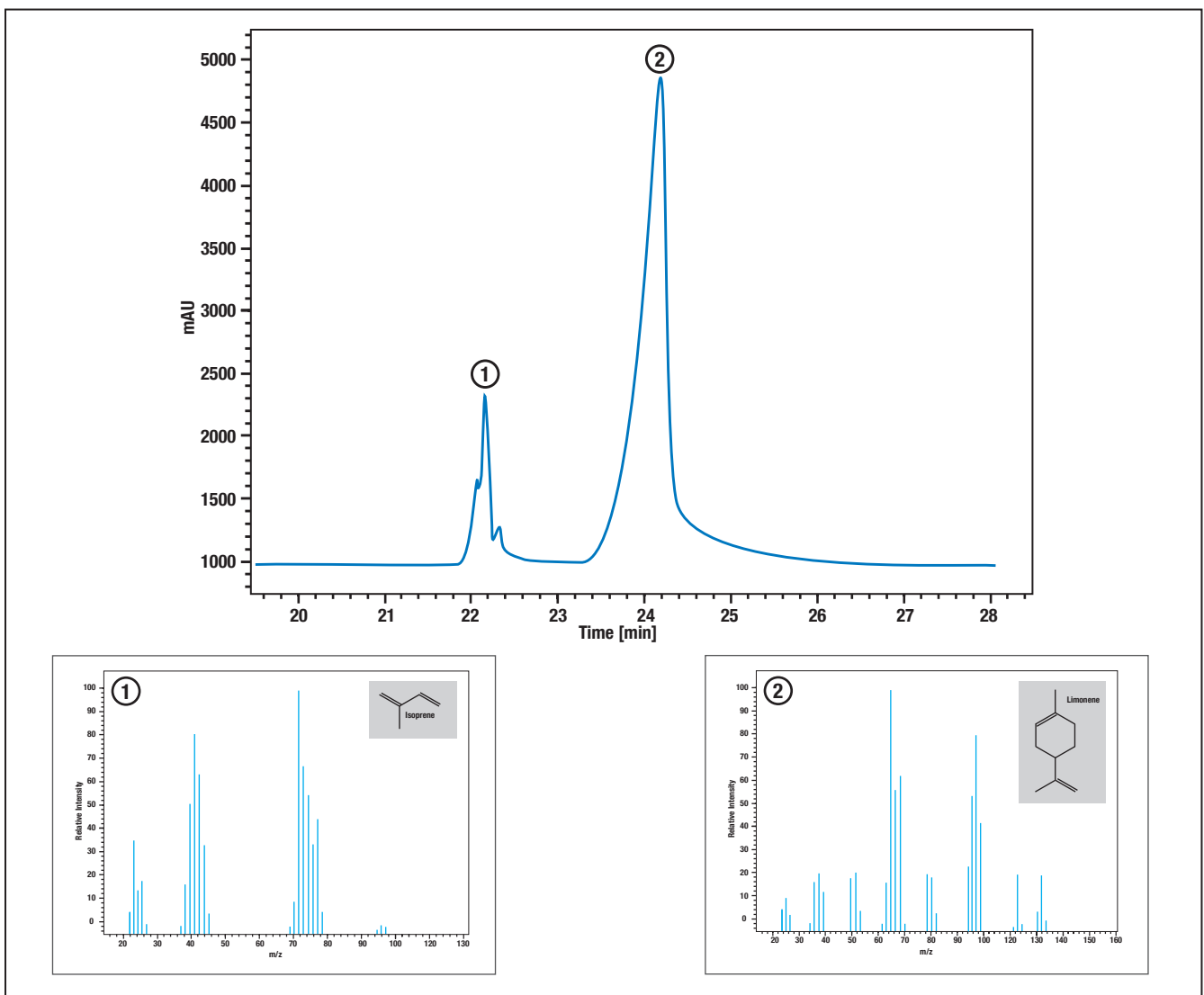

## Possible Techniques:

- FTIR: Fourier Transform Infrared Spectroscopy: Measurement of basic and trace gas components until ppm range (for example  $\text{H}_2\text{O}$ ,  $\text{CO}_2$ ,  $\text{CO}$ ,  $\text{H}_2\text{S}$ ...). Polar Molecules are necessary.
- Raman-Spectroscopy: Measurement of basic gas components. Also not polar molecules like  $\text{H}_2$  or  $\text{N}_2$  are measurable.
- ELIF: Excimer Laser induced Fragmentation Fluorescence: UV-Laser-based Method of Measuring of gaseous alkaline compounds (for example  $\text{NaCl}$ ,  $\text{NaOH}$ ,  $\text{KCl}$ ,  $\text{KOH}$ ). Also at 193 nm an entry through UV\_Saphire is possible.

## Advantages of the optical In-Situ window:

- No cooling / modification of the measuring gas (for example no out-condensation, no transition reaction, no equilibrium shift)
- Many materials with high condensation temperature for example alkali metals ( $\text{Na}$ ,  $\text{K}$  and their combinations) are now able to be measured, heated capillary only suitable for some 200 - 250°C, the optical port allows measurement until 1600°C
- No intervention into the measuring system (for example when pulling gas by vacuum)
- No contamination of the measuring gas in the capillary to M/S or FTIR
- Real-time online-measurement (no dead time until measuring volume enters the measuring instrument)

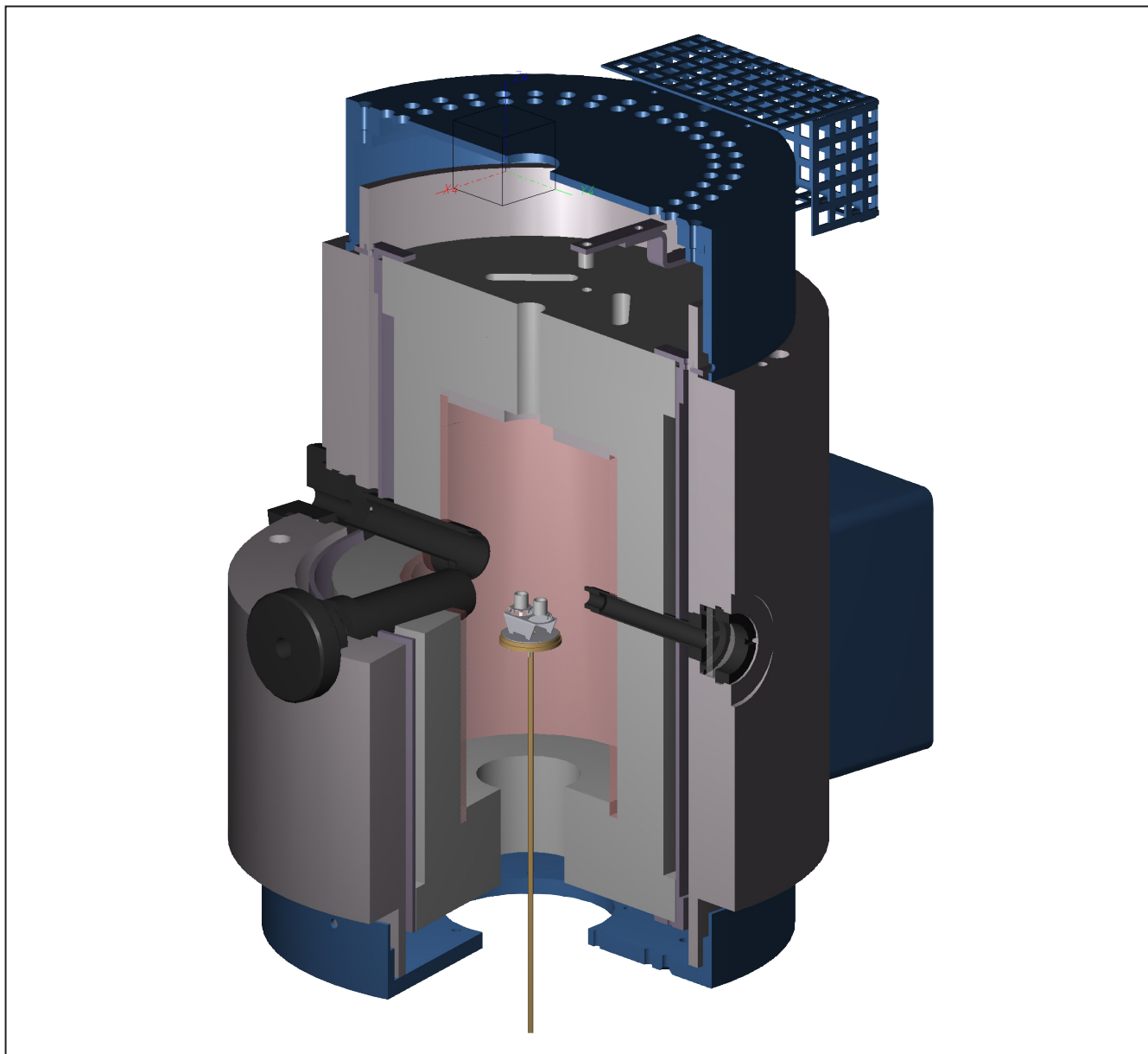



<b>LINSEIS GmbH</b>	<b>LINSEIS Inc.</b>
Vielitzerstr. 43	109 North Gold Drive
95100 Selb	Robbinsville, NJ 08691
Germany	USA
Tel.: (+49) 9287-880 - 0	Tel.: +01 (609) 223 2070
Fax: (+49) 9287-70488	Fax: +01 (609) 223 2074
E-mail: <a href="mailto:info@linseis.de">info@linseis.de</a>	E-mail: <a href="mailto:info@linseis.com">info@linseis.com</a>

**Products:** DIL, TG, STA, DSC, HDSC, DTA, TMA, MS/FTIR, In-Situ EGA, Laser Flash, Seebeck Effect  
**Services:** Service Lab, Calibration Service

[www.linseis.com](http://www.linseis.com)